

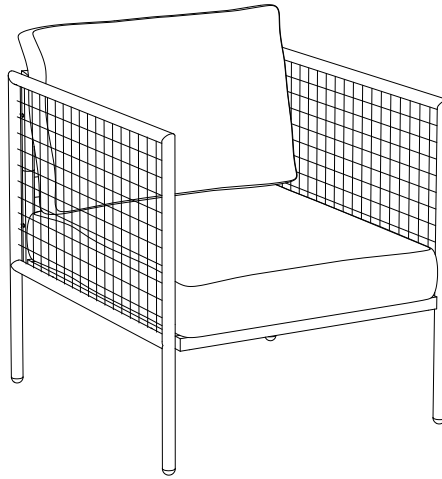







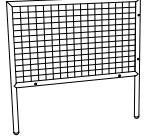
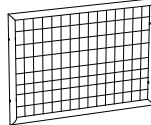

Outdoor Wicker Arm Chair
CO6233

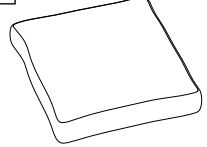

PART LIST

<p>A</p> 	<p>B</p> 	<p>C</p> 	<p>D</p> 	<p>E</p> 
<p>Right Arm Panel 2 PCS</p>	<p>Left Arm Panel 2 PCS</p>	<p>Back Panel 2 PCS</p>	<p>Seat Panel 2 PCS</p>	<p>Seat Cushion 2 PCS</p>
<p>F</p>  <p>Back Cushion 2 PCS</p>				



HARDWARE LIST

<p>#1</p>  <p>M6*45mm</p>	<p>#2</p>  <p>M6mm</p>	<p>#3</p>  <p>M6mm</p>
<p>Bolt 18 PCS (Extra 1)</p>	<p>Flat Washer 18 PCS (Extra 1)</p>	<p>Allen Wrench 1 PC</p>

Step 1. Lay back panel (part C) down on a soft flat surface, such as carpet, as shown below. Attach seat panel (part D) to back panel (part C) using bolt (part #1), flat washer (part #2) and allen wrench (part #3).

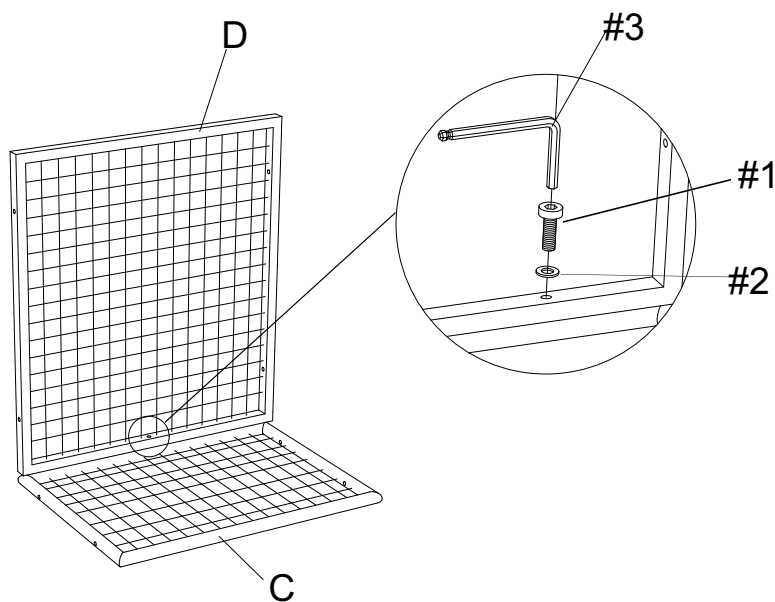
NOTE: Please do not fully tighten bolts until unit is fully assembled.





- | | | |
|----|---|----|
| #1 |  | x1 |
| #2 |  | x1 |
| #3 |  | x1 |

Step 2. Attach left arm panel (part B) to back panel (part C) and seat panel (part D) using bolts (part #1), flat washers (part #2) and allen wrench (part #3).

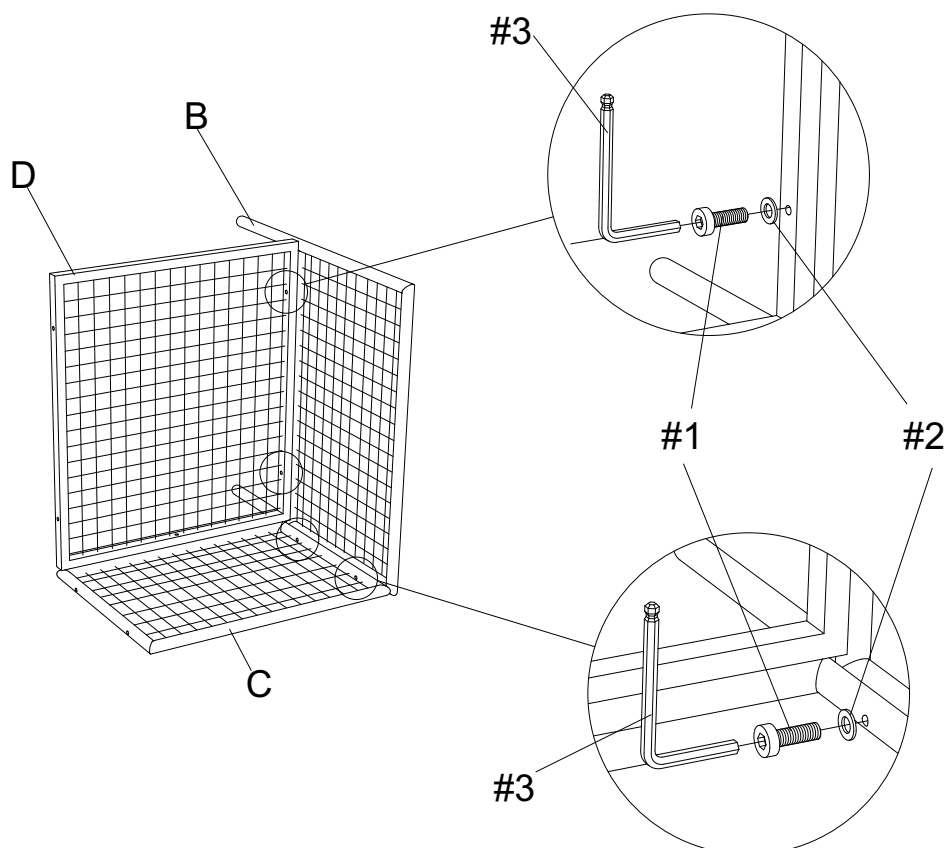
NOTE: Please do not fully tighten bolts until unit is fully assembled.



- | | | |
|----|---|----|
| #1 |  | x4 |
| #2 |  | x4 |
| #3 |  | x1 |

Step 3. Attach right arm panel (part A) to seat panel (part D) and back panel (part C) using bolts (part #1), flat washers (part #2) and allen wrench (part #3).

NOTE: Please fully tighten all bolts at this time.

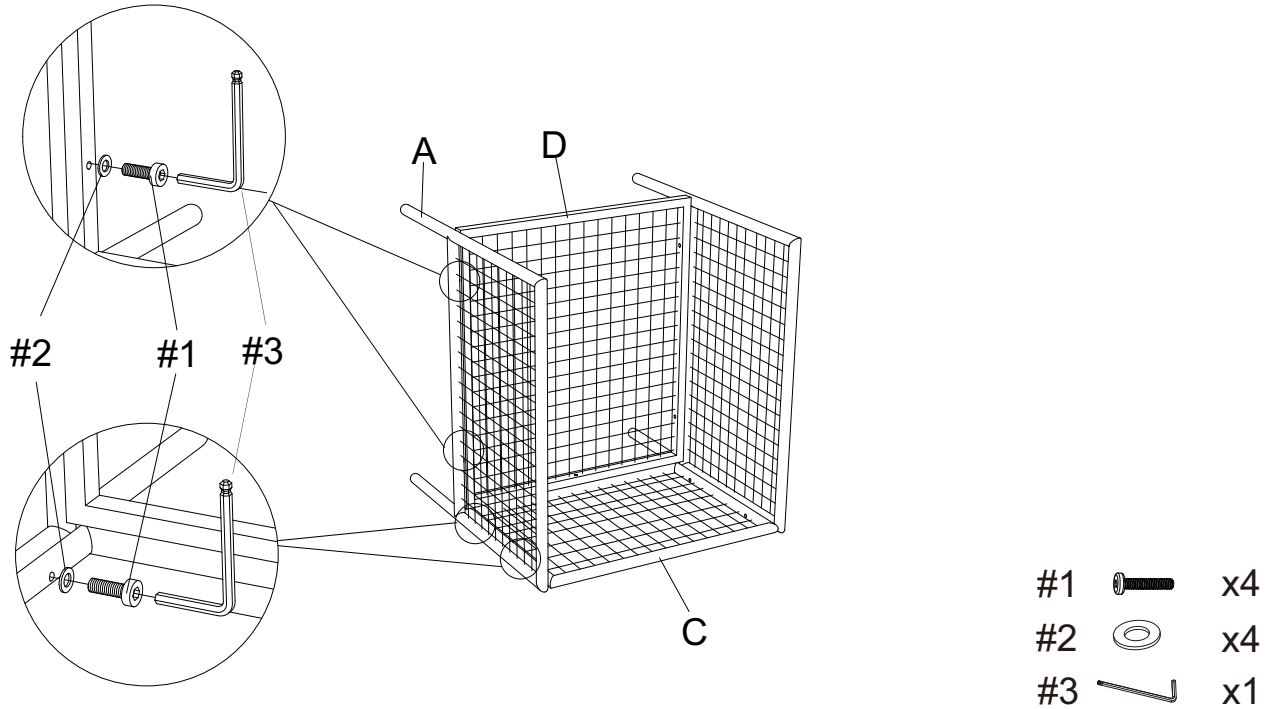

Step 4. Carefully turn unit upright. Place seat cushion (part E) and back cushion (part F) as shown below.

Repeat steps 1-4 to assemble remaining chair.

