

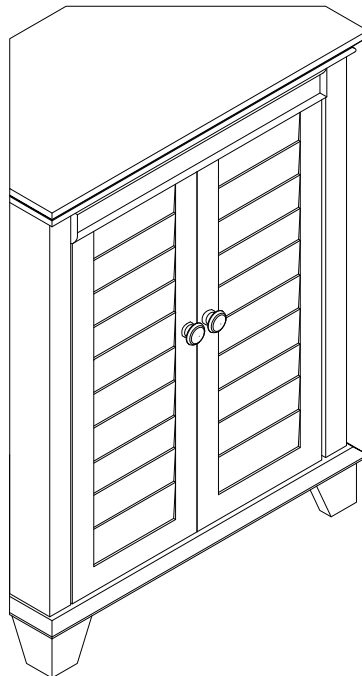









Corner Cabinet

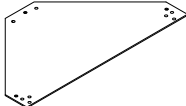
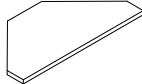

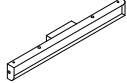
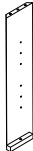
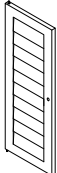

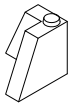



CF7021

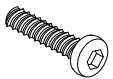
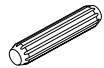

PART LIST

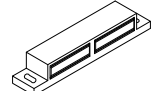
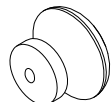
<p>A</p> 	<p>B</p> 	<p>C</p> 	<p>D</p> 	<p>E</p> 
<p>Top Panel 1 PC</p>	<p>Bottom Panel 1 PC</p>	<p>Adjustable Shelf 2 PCS</p>	<p>Right Panel 1 PC</p>	<p>Left Panel 1 PC</p>
<p>F</p> 	<p>G</p> 	<p>H</p> 	<p>I</p> 	<p>J</p> 
<p>Front Rail 1 PC</p>	<p>Middle Back Panel 1 PC</p>	<p>Left Door Panel 1 PC</p>	<p>Right Door Panel 1 PC</p>	<p>Back Panel 2 PCS</p>
<p>K</p> 	<p>L</p> 			
<p>Foot 2 PCS</p>	<p>Support Leg 1 PC</p>			

HARDWARE LIST

<p>#1</p>  <p>Φ1/4"*1"</p> <p>Bolt 7 PCS</p>	<p>#2</p>  <p>Φ8*30mm</p> <p>Wood Dowel 18 PCS (Extra 2)</p>	<p>#3</p>  <p>Ø5/32"*19mm</p> <p>Round Head Bolt 2 PCS</p>	<p>#4</p>  <p>Ø4*32mm</p> <p>Long Screw 2 PCS</p>	<p>#5</p>  <p>Φ3*12mm</p> <p>Short Screw 24 PCS (Extra 2)</p>
<p>#6</p>  <p>Φ3*16mm</p> <p>Screw 2 PCS</p>	<p>#7</p>  <p>Double Magnet 1 PC</p>	<p>#8</p>  <p>Knob 2 PCS</p>	<p>#9</p>  <p>Shelf Holder 6 PCS (Extra 1)</p>	<p>#10</p>  <p>M4 Allen Wrench 1 PC</p>
<p>#11</p>  <p>Safety Strap Kit 1 SET</p>				

ADDITIONAL TOOLS (Not Provided)

Note: It is not recommended to use power tools during assembly.

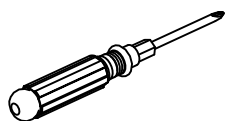



Phillips Head Screwdriver

Note: Wood dowels are intended for alignment. Additional clearance between wood dowel and pre-drilled hole is intentional for ease of assembly.

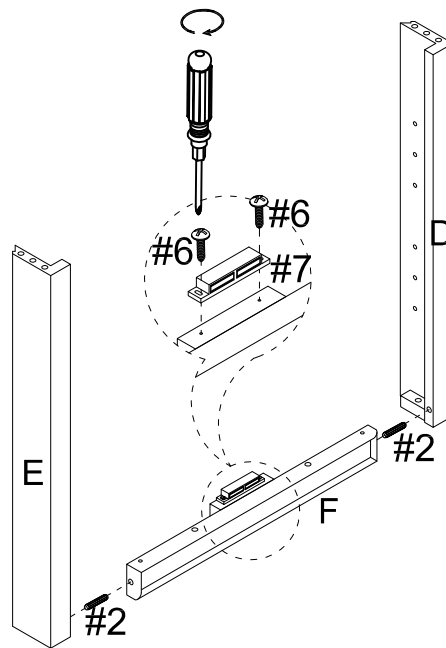



Step 1. Attach double magnet (part #7) to front rail (part F) using screws (part #6) and phillips head screwdriver. Attach panels (parts D & E) to front rail (part F) using wood dowels (part #2).

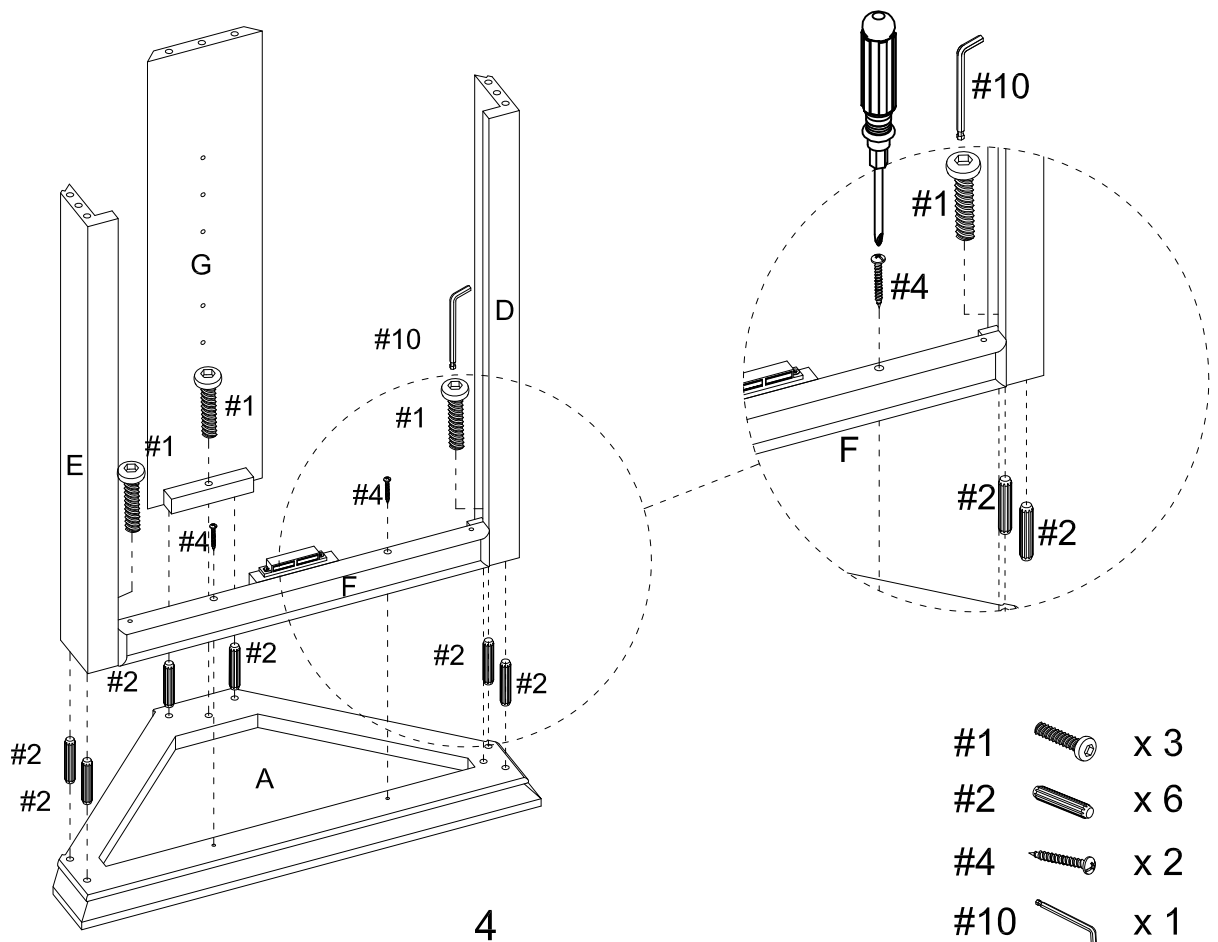

- | | | |
|----|---|-----|
| #2 |  | x 2 |
| #6 |  | x 2 |
| #7 |  | x 1 |



Step 2. Lay top panel (part A) upside down on a soft flat surface, such as carpet, as shown below. Attach assembled unit (parts D, E & F) and middle back panel (part G) to top panel (part A) using wood dowels (part #2), bolts (part #1), long screws (part #4), allen wrench (part #10) and phillips head screwdriver.



- | | | |
|-----|---|-----|
| #1 |  | x 3 |
| #2 |  | x 6 |
| #4 |  | x 2 |
| #10 |  | x 1 |

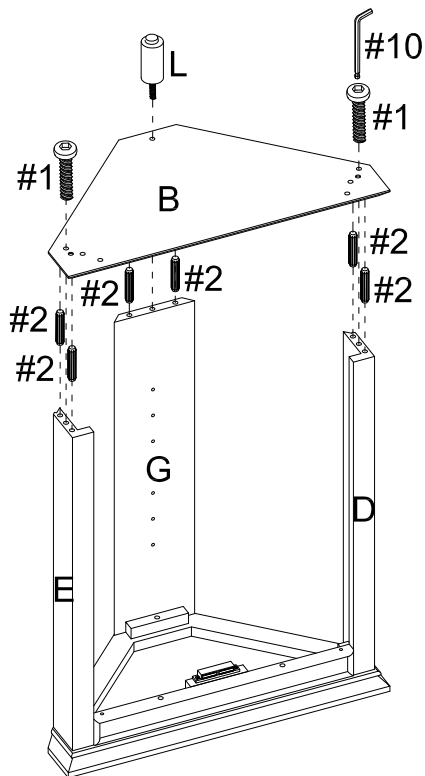

Step 3. Attach bottom panel (part B) to assembled unit (parts D, E & G) using wood dowels (part #2), bolts (part #1), support leg (part L) and allen wrench (part #10).

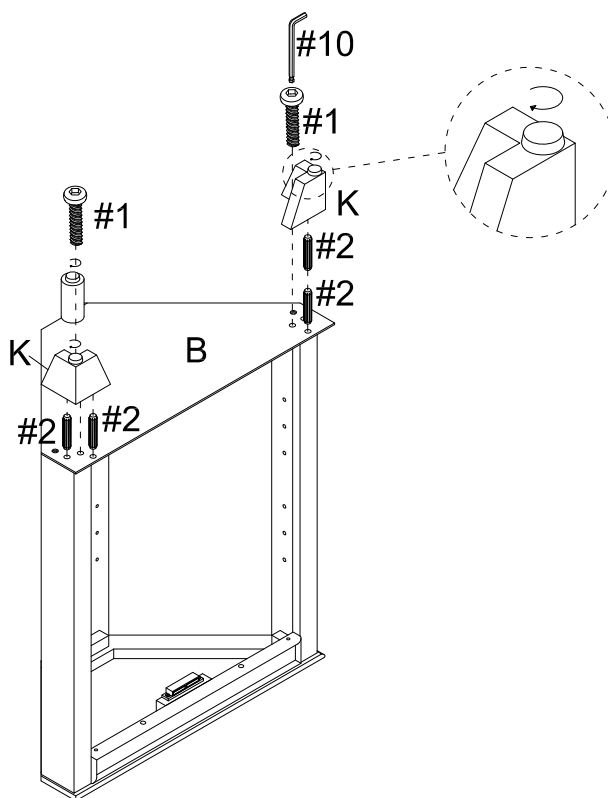

- | | | |
|-----|---|-----|
| #1 |  | x 2 |
| #2 |  | x 6 |
| #10 |  | x 1 |

Step 4. Attach feet (part K) to bottom panel (part B) using wood dowels (part #2), bolts (part #1) and allen wrench (part #10).



- | | | |
|-----|---|-----|
| #1 |  | x 2 |
| #2 |  | x 4 |
| #10 |  | x 1 |

Step 5. Carefully turn unit upright. Attach back panels (part J) to assembled unit (parts A, B, D, E & G) using short screws (part #5) and phillips head screwdriver.

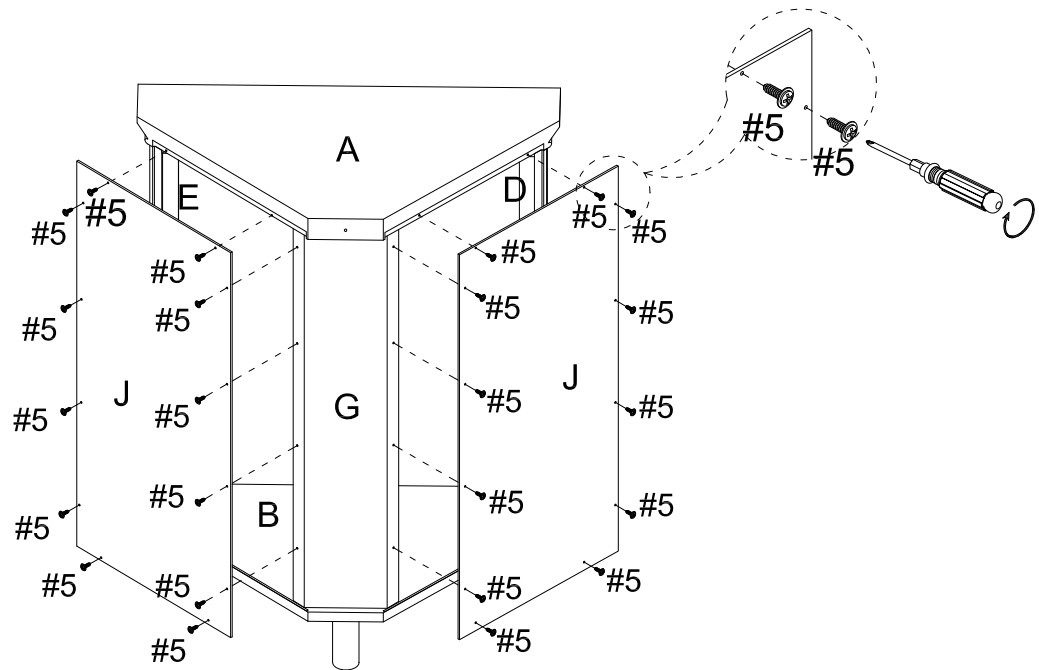

#5  x 24

Step 6. Place shelf holders (part #9) into desired position and slide adjustable shelves (part C) into place.

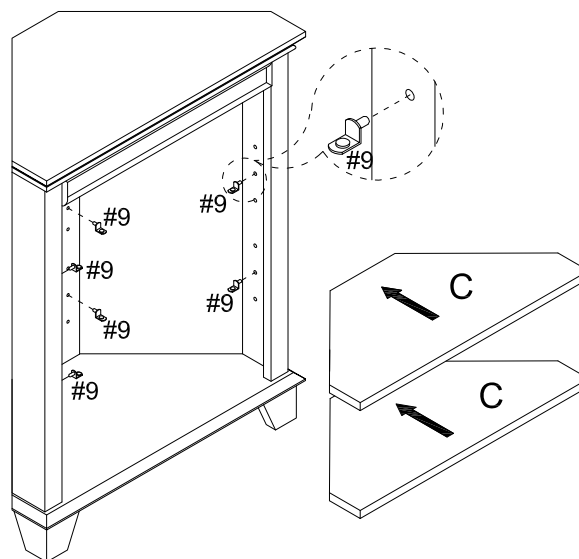

6

#9  x 6

Step 7. Attach door panels (parts H & I) by placing bottom pin hinge (pre-installed in door) in the pre-drilled hole of bottom panel (part B). Then depress the top spring-loaded pin hinge so it can be placed in the pre-drilled hole of front rail (part F). Attach knobs (part #8) to door panels (parts H & I) using round head bolts (part #3) and phillips head screwdriver.





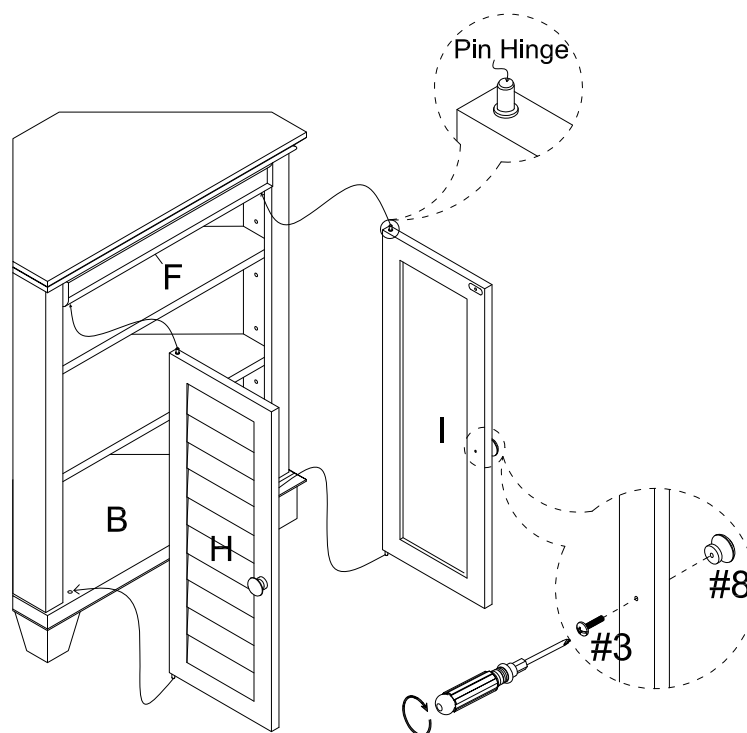

NOTE: Be sure top and bottom pin hinges are fully extended to secure doors in place.

NOTE: It is important to adjust levelers once fully assembled and upright. Extend adjustable leveler until it's firmly in contact with the floor. If relocating, adjust leveler as needed until it's firmly in contact with the floor in new location.

Important: Safety strap kit (part #11) must be installed to prevent tipping, damage and/or injury.



#3		x 2
#8		x 2

#11	A	B	C	D	E
					
	1-1/2"xØ4xD8		5/8"xØ3xD8		
Safety Strap Kit 1 SET	Long Screw 1 PC	Wall Anchor 1 PC	Short Screw 1 PC	Safety Wall Strap 1 PC	Flat Washer 1 PC

SAFETY WALL STRAP INSTALLATION

Note: It is highly recommended to install this safety strap kit to prevent tipping, damage and/or injury.

1. Insert short screw (C) through flat washer (E) and safety wall strap (D) and attach to top panel (part A) using phillips head screwdriver.
2. Drill a 11/32" hole where you want to secure the unit. The drilled hole will be at the same height as the hole in top panel (part A) where safety wall strap (D) is attached. Tap wall anchor (B) into the hole.
3. Insert long screw (A) through safety wall strap (D) into wall anchor (B) using phillips head screwdriver.

Note: This item is not intended for clothing storage use.

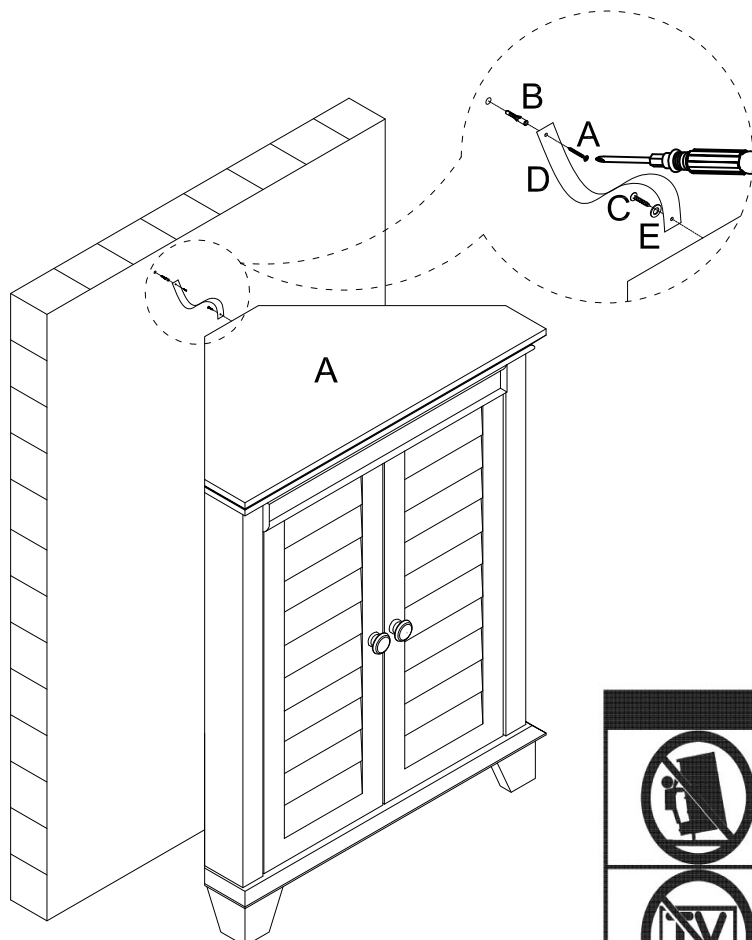

⚠ WARNING	
 	<p>Children have died from furniture tipover. To reduce the risk of furniture tipover:</p> <ul style="list-style-type: none"> • ALWAYS install tipover restraint provided. • NEVER put a TV on this product. • NEVER allow children to stand, climb or hang on drawers, doors, or shelves. • NEVER open more than one drawer at a time. • Place heaviest items in the lowest drawers. <p><i>This is a permanent label. Do not remove!</i></p>