

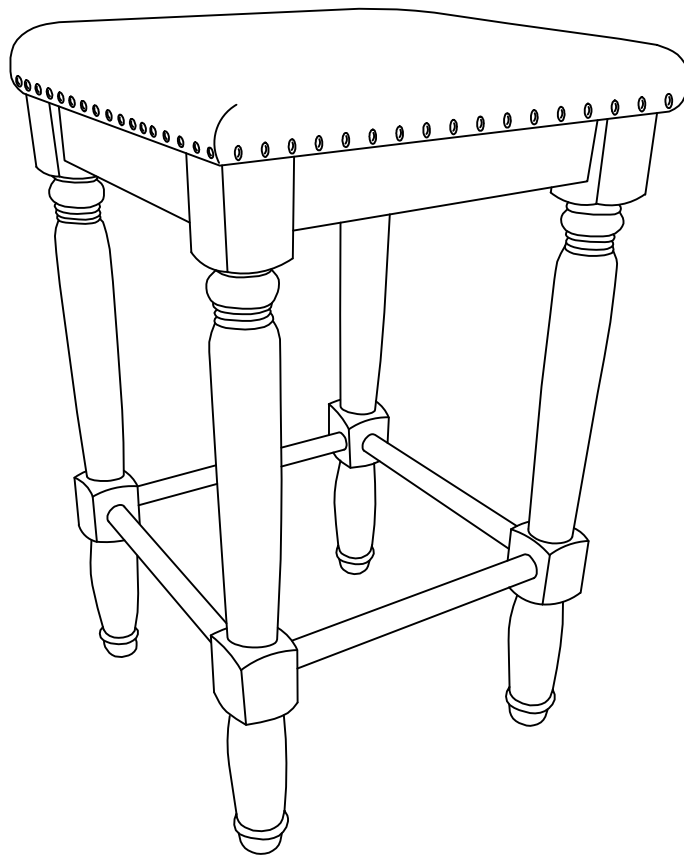

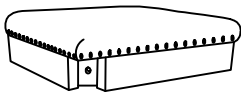

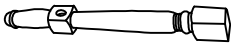



Counter Stool
CF502126

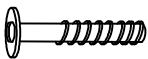

PART LIST

<div data-bbox="172 181 220 226" data-label="Text">#A</div> 	<div data-bbox="427 181 475 226" data-label="Text">#B</div> 	<div data-bbox="679 181 727 226" data-label="Text">#C</div> 
<div data-bbox="209 465 384 533" data-label="Text"> <p>Seat Frame 2 PCS</p> </div>	<div data-bbox="507 465 596 533" data-label="Text"> <p>Leg 8 PCS</p> </div>	<div data-bbox="730 465 863 533" data-label="Text"> <p>Strecher 8 PCS</p> </div>

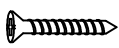
HARDWARE LIST

<div data-bbox="164 678 220 723" data-label="Text">#1</div> 	<div data-bbox="419 678 475 723" data-label="Text">#2</div> 	<div data-bbox="671 678 727 723" data-label="Text">#3</div> 	<div data-bbox="917 678 973 723" data-label="Text">#4</div> 	<div data-bbox="1169 678 1225 723" data-label="Text">#5</div> 
<div data-bbox="212 902 379 936" data-label="Text"> <p>M8 x 50mm</p> </div>			<div data-bbox="967 902 1134 936" data-label="Text"> <p>M4 x 38mm</p> </div>	<div data-bbox="1278 902 1334 936" data-label="Text"> <p>M5</p> </div>
<div data-bbox="193 965 400 1032" data-label="Text"> <p>Bolt 8 PCS (Extra 2)</p> </div>	<div data-bbox="432 965 644 1032" data-label="Text"> <p>Spring Washer 8 PCS (Extra 2)</p> </div>	<div data-bbox="695 965 900 1032" data-label="Text"> <p>Flat Washer 8 PCS (Extra 2)</p> </div>	<div data-bbox="943 965 1161 1032" data-label="Text"> <p>Screw 16 PCS (Extra 2)</p> </div>	<div data-bbox="1209 965 1401 1032" data-label="Text"> <p>Allen Wrench 1 PC</p> </div>

ADDITIONAL TOOLS (Not Provided)

Note: It is not recommended to use power tools during assembly.

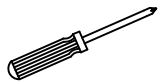

Phillips Head Screwdriver

Step 1. Carefully turn seat frame (part A) upside down on a flat, soft surface, such as carpet. Attach legs (part B) to seat frame (part A) using bolts (part #1), spring washers (part #2), flat washers (part #3) and allen wrench (part #5).

NOTE: Please do not fully tighten bolts until unit is fully assembled.

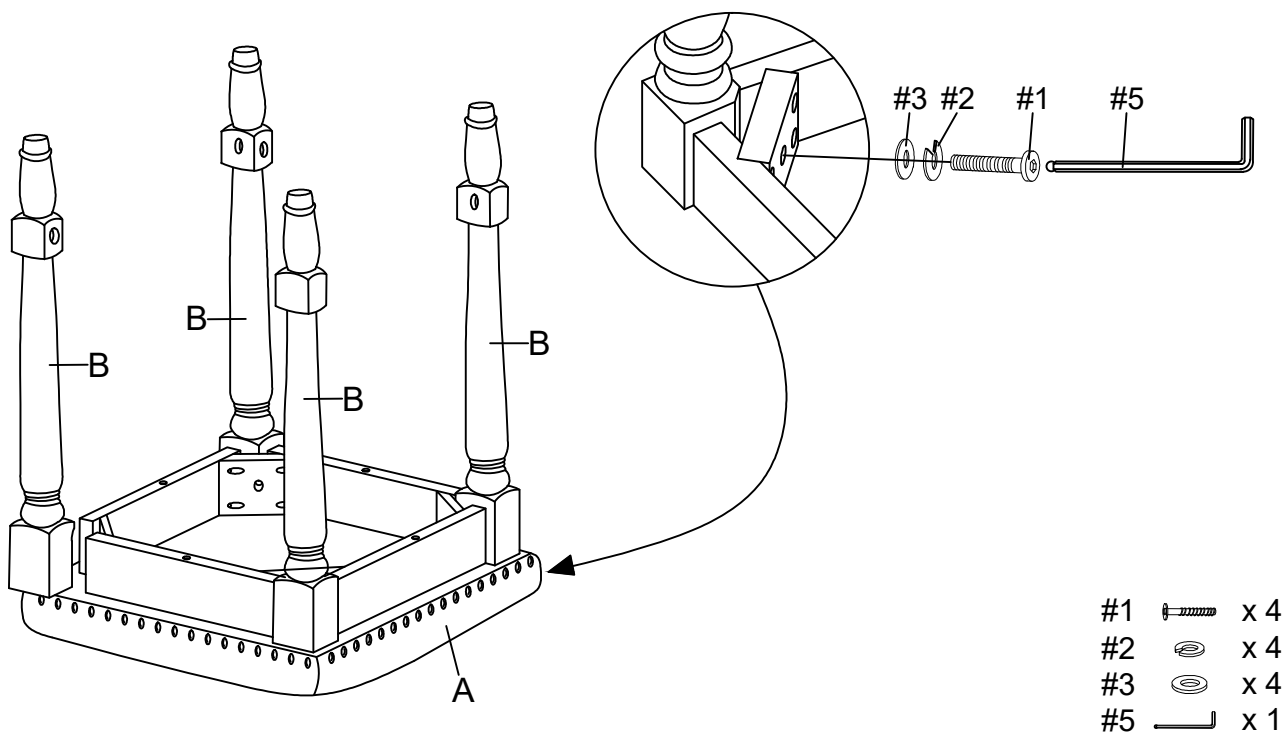

Step 2. Insert stretchers (part C) into legs (part B) using screws (part #4) and phillips head screwdriver.

NOTE: Please fully tighten all bolts at this time.

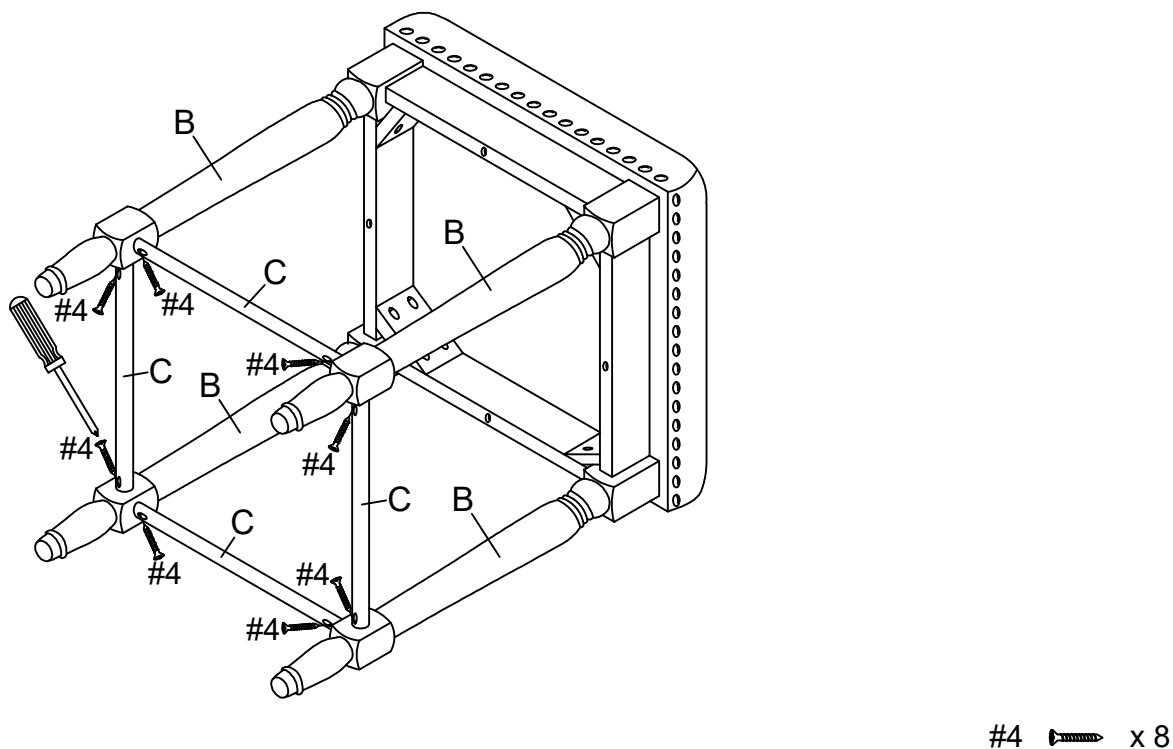

Step 3. Carefully turn unit upright. Repeat steps 1-2 to assemble remaining stool.

