

CROSLEY

FURNITURE

Dining Table

CF2002

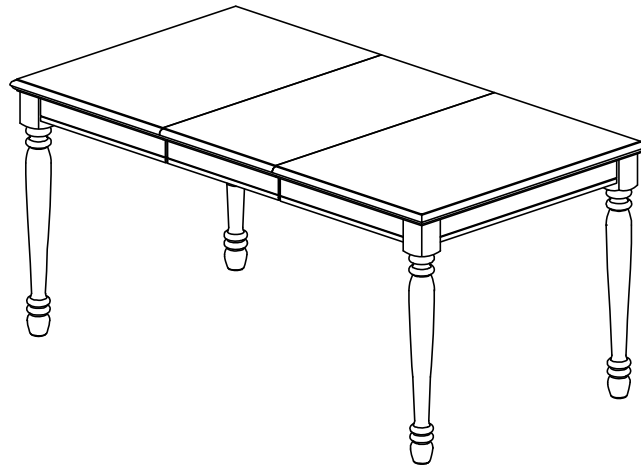

PART LIST

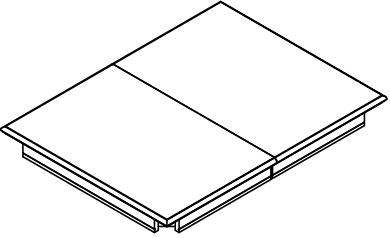
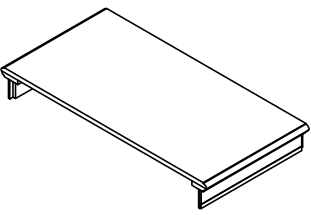
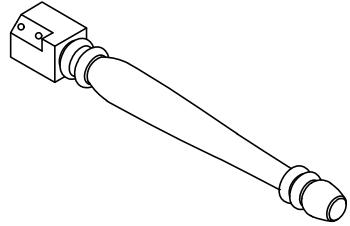
<div data-bbox="119 134 167 190" data-label="Text"> <p>A</p> </div> 	<div data-bbox="582 134 630 190" data-label="Text"> <p>B</p> </div> 	<div data-bbox="1045 134 1093 190" data-label="Text"> <p>C</p> </div> 
<p>Table Top 1 PC</p>	<p>Table Leaf 1 PC</p>	<p>Leg 4 PCS</p>

HARDWARE LIST

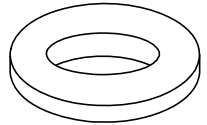
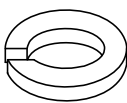
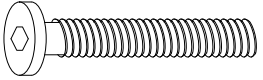
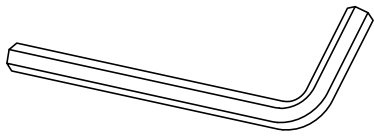
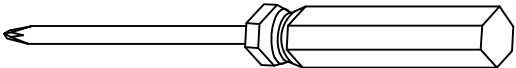
<div data-bbox="103 936 175 996" data-label="Text"> <p>#1</p> </div>  <p>1/4"</p>	<div data-bbox="566 936 638 996" data-label="Text"> <p>#2</p> </div>  <p>1/4"</p>	<div data-bbox="1029 936 1101 996" data-label="Text"> <p>#3</p> </div>  <p>M8 x 60mm</p>
<p>Flat Washer 8 PCS (Extra 2)</p>	<p>Spring Washer 8 PCS (Extra 2)</p>	<p>Bolt 8 PCS (Extra 2)</p>
<div data-bbox="103 1518 175 1579" data-label="Text"> <p>#4</p> </div>  <p>M5</p> <p>Allen Wrench 1 PC</p>	<p>ADDITIONAL TOOLS (Not Provided)</p> <p>Note: It is not recommended to use power tools during assembly.</p>  <p>Phillips Head Screwdriver</p>	

Step 1. Before assembly remove two corner connectors (See Figure 1) using phillips head screwdriver. Carefully turn table top (part A) upside down on a soft flat surface, such as carpet. Attach legs (part C) to table top (part A) using flat washers (part #1), spring washers (part #2), bolts (part #3) and allen wrench (part #4).

Note: Please fully tighten all bolts.

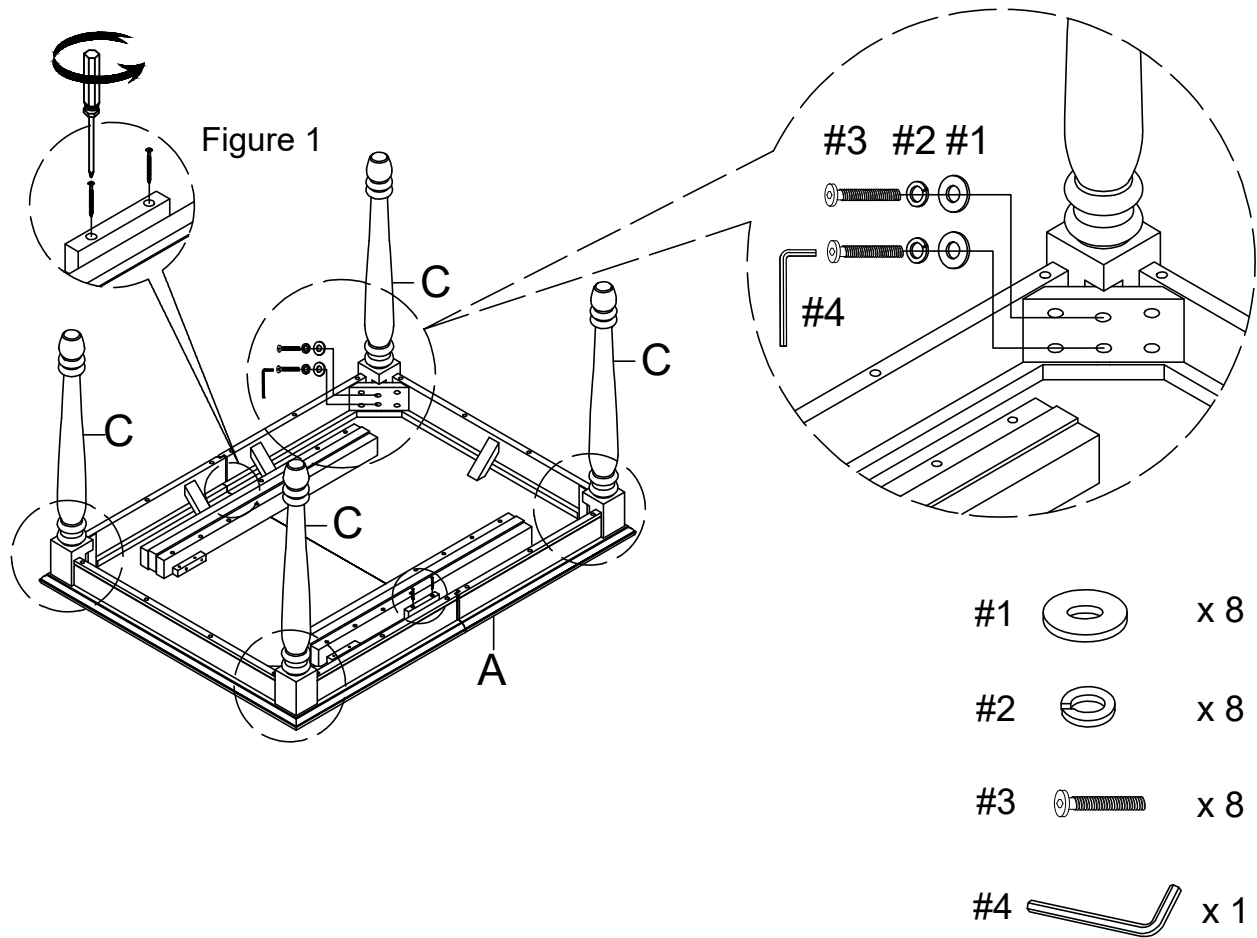

Step 2. Carefully turn unit upright. To insert table leaf (part B), unlock the clamp locks underneath table top (part A) and pull on opposite ends to separate.

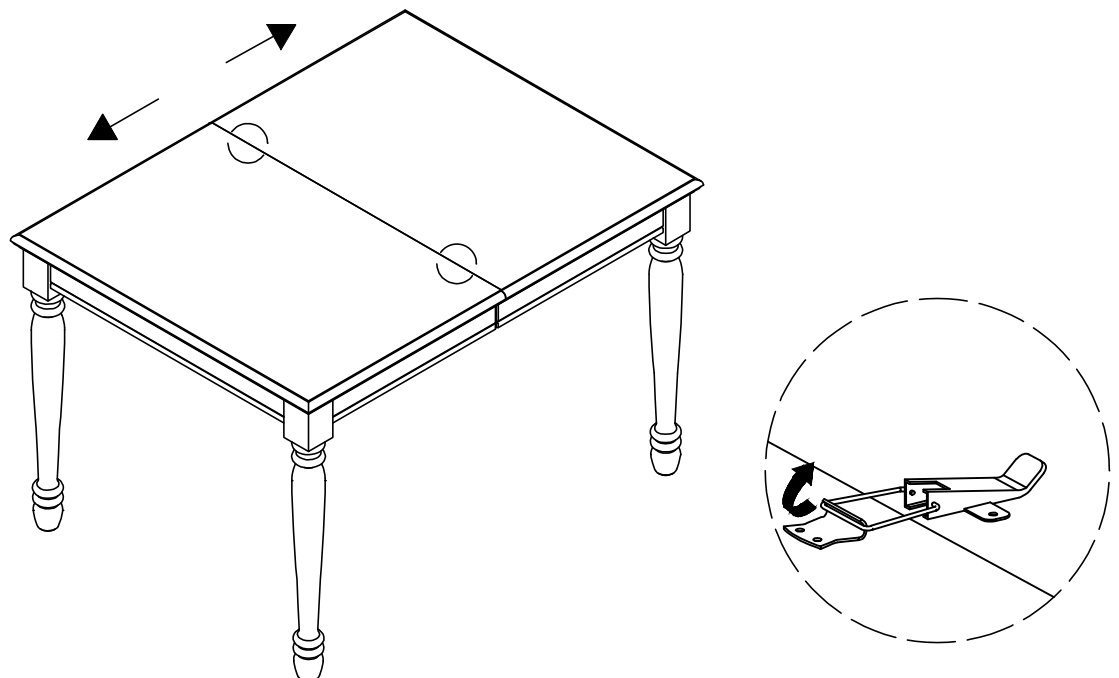

Step 3. Place table leaf (part B) in position and push table top (part A) from both ends to close.

Note: Ensure clamp locks line up correctly when inserting table leaf (part B).

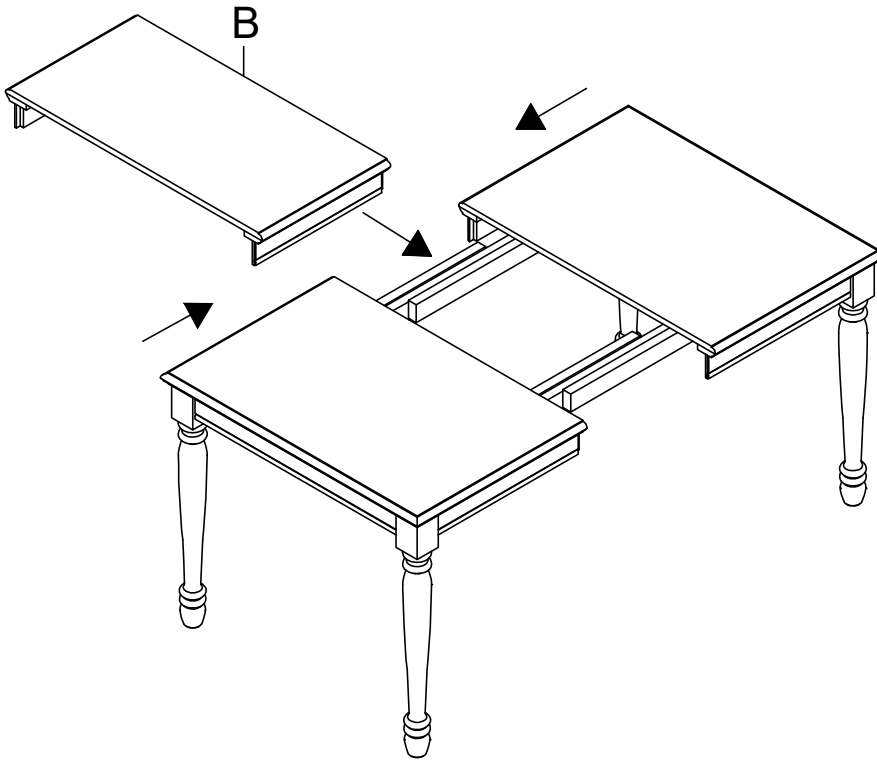

Step 4. Lock clamp locks underneath table top (part A) to secure.

